



The *Raymond*[®] Walkie Pallet Truck Model 102XM

The rugged 4,500 lb. capacity *Raymond*[®] 102XM Walkie Pallet Truck is a low cost, highly maneuverable, ergonomically designed performer. It's ideal for crowded loading docks, congested aisles – and especially those tight spaces inside trailers.

The unique handle provides smooth, comfortable control as the operator walks. Whether traveling tractor-first or forks-first, the truck's direction and speed are controlled with convenient thumb wheels. This allows one-handed operation for forward, reverse, lift, lower or horn. In addition, easy-to-read displays on the handle include battery discharge indicator, hour meter and error code display.

Get these advantages with the 102XM

- Easily perform 180° pinwheeling for loading and unloading
- Program performance to match operator skill level
- Tilt handle up to operate in tight places
- Maneuver easily over floor obstacles
- Enjoy fast, easy servicing
- Choose standard or cold storage conditioning packages
- Get long term dependability with tough, durable design

RAYMOND
Above. And beyond.[®]

www.raymondcorp.com

Specifications—Walkie Model 102XM

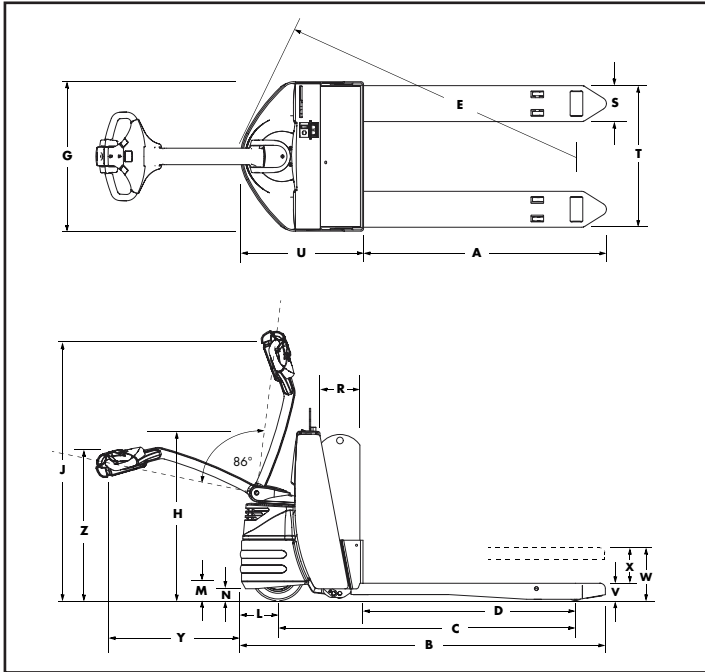

DIMENSIONS AND SPECIFICATIONS		102XM		
Nominal Fork Length †	in.	36	42	48
A Actual Fork Length	in.	33.5	39.5	45.5
B Overall Length	in.	56.6	62.6	68.6
C Wheelbase, Lowered/Raised	in.	43.9/40.8	49.9/46.8	55.9/52.8
D Load Wheel Location, Lowered/Raised	in.	27.9/24.6	33.9/30.6	39.9/36.6
G Truck OAW	in.	28		
H Power Unit Height	in.	31.9		
J Control Handle Height	in.	48.6		
L Bumper to Drive Tire Center	in.	7.0		
M Bumper Underclearance	in.	3.0		
N Toe Underclearance	in.	2.2		
R Battery Compartment Width *	in.	7.8		
S Fork Width (each)	in.	6.75		
T Fork OAW, Nominal/Actual †**	in.	22/21.5		27/26.5
U Head Length	in.	23		
V Fork Down Height	in.	3.25		
W Elevated Height	in.	8.65		
X Lift	in.	5.4		
Y Handle Length	in.	27.8		
Z Handle to Floor	in.	25.9		
Drive Tire, rubber	in.	10 x 5		
Load Wheels, polyurethane	in.	3.25 x 4.5		
Truck Weight, less battery	lbs.	600		
Battery Connector		SB-175 red		
Battery Lead Position/Length	in.	B/18		
Battery Voltage	V	24		
Minimum Battery Weight	lbs.	200		

* 9.0 in. Battery Compartment is available as an option.

** Actual Fork OAW is .5 in. narrower than Nominal Fork OAW for added truck maneuverability.

† Other widths and lengths available.

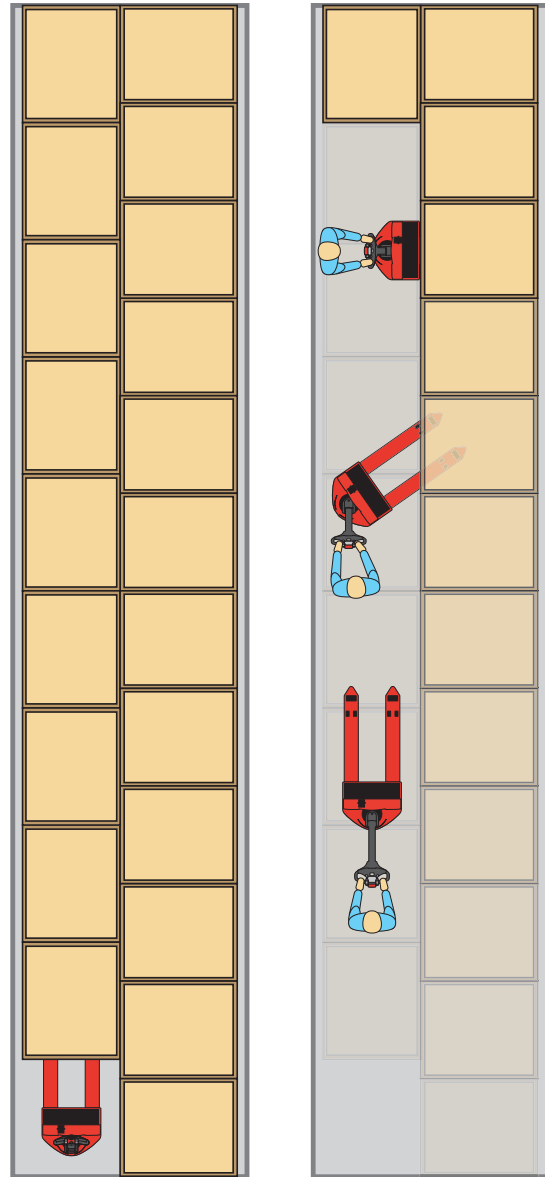

Right angle stacking illustrated with standard GMA pallet (40"x48").

PERFORMANCE SPECIFICATIONS		102XM	
Capacity	lbs.	4500	
Gradability	empty/loaded	%	10/6 (4500 lb. load)
Gradability	empty/loaded	%	10/10 (2500 lb. load)
Lift Time	empty/loaded	sec.	3.0/3.9
Travel Speed	empty/loaded	mph	3.8/3.4
Turning Radius *	lowered/raised	in.	62.9/59.8
Right Angle Stacking *		in.	94.5

* For 48" truck.

RAYMOND
Above. And beyond.®

The Raymond Corporation
P.O. Box 130
Greene, New York 13778-0130
Toll free 1 (800) 235-7200
Fax 1 (607) 656-9005

www.raymondcorp.com